

AUTO START 23cond. WIRING HARNESS, ALL WIRES 20 FEET

(PLUG SIDE)

FACE/PLUG SIDE OF HDP26-24-21SE
OR BACK SIDE OF HDP24-24-21PE SHOWN

Note: All wires are from 19-strand 18awg sheathed cable unless otherwise specified
The higher-power wires are specified as 12awg on the drawing

PIN	NAME	AWG	COL
A	EXPANSION	18	BRN
B	GND	12	BLK
C	OIL_PRESS	18	ORA
D	STARTER	12	RED
E	IGNITION	12	GRN
F	IGNITION	18	YEL
G	PRIME	12	WHT
H	SPEED DEC	18	GRN
J	EXPANSION	18	BLU
K	ENGINE TEMP	18	PUR
L	LOW DISCH	18	GRY
M	GND	18	WHT
N	SPEED INC	18	BGE
P	IGNITION	18	PNK
R	ENGINE RPM.(OPT)	18	RED/BLK
S	IGNITION	18	RED/YEL
T	DISCH PRESS	18	RED/GRN
U	GND	18	WHT/BLK
V	+12V	18	WHT/RED
W	OPL INC	18	WHT/YEL
X	OPL DEC	18	WHT/GRN

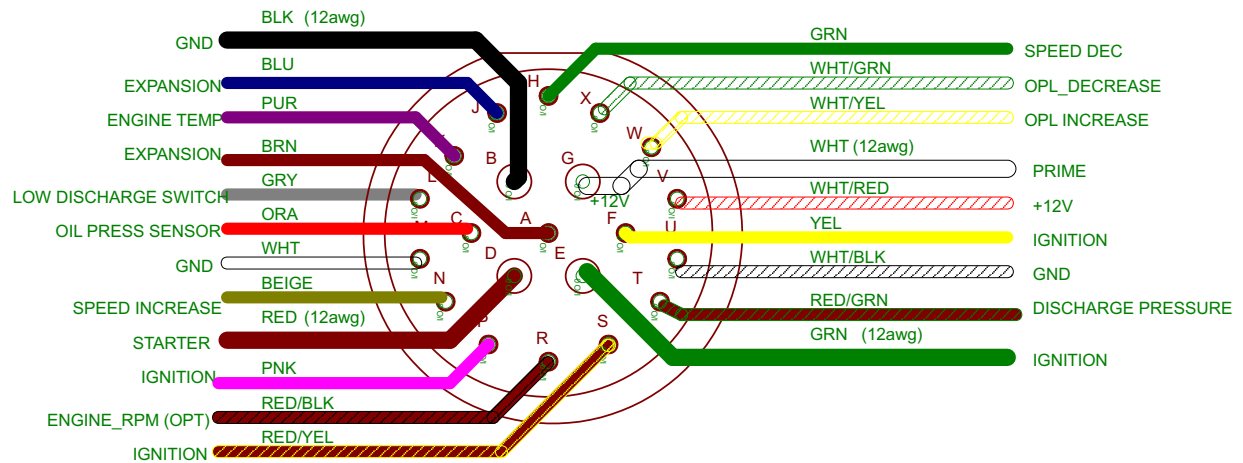

TITLE: AutoStartMechCable_Deutsch_plug	
Document Number:	REU:
Date: 2/14/2013 10:36:32 AM	Sheet: 1/1